

DIP Switch

NOTE: Before adjusting the configuration of the DIP Switch, the power should be **OFF**.

DIP SW	Function	OFF (Default)	ON
1	External Port Link	Disable	Enable
	<p>ON: Triggers an alarm if any fiber or copper port loses link. The red Alarm LED turns on and the normally open alarm relay closes.</p> <p>OFF: No alarm is triggered for port link loss.</p> <p>During startup, the Alarm LED briefly turns on, and the relay momentarily closes as part of normal initialization.</p>		
2	PoE Trigger	Disable	Enable
	<p>This feature is only available when SW 5 is set to ON (Converter Mode) and SW 6 is set to OFF (2-Pair Mode).</p> <p>ON: If Fiber port 1 loses its link, copper port 1 will drop the link and PoE power will be disabled. If fiber port 2 loses its link, copper port 2 will drop the link and PoE power will be disabled.</p> <p>Note: this can effectively reboot a remote PoE/PD by disabling or disconnecting the fiber at the local end.</p> <p>OFF: Disables this feature which can make troubleshooting link failures easier.</p>		
3	Fiber Speed	1000Mbps	100Mbps
	<p>Sets the operating speed of both SFP ports.</p> <p>OFF (Default): 1000 Mbps (1 Gbps)</p> <p>ON: 100 Mbps</p> <p>*it is not possible to set one SFP port to 100mbps and the other to 1000mbps</p>		
4	Fiber Mode	Auto-Negotiation Mode	Force Mode
	<p>This setting is only effective when SW 3 (Fiber Speed) is set to OFF (1000 Mbps).</p> <p>ON: Forced Gigabit speed</p> <p>OFF: Auto-Negotiation</p> <p>*Auto negotiate is only available in 1000mbps fiber. Both ends of the fiber should be set to the same either Auto-Negotiation or Forced.</p>		
5	Operation Mode	Switch Mode	Converter Mode
	<p>ON: Converter mode: In this mode, the unit operates as two independent media converters: Fiber Port 1 is paired with Copper Port 1, and Fiber Port 2 is paired with Copper Port 2. SW 6 must be in OFF-2 pair mode.</p> <p>OFF: Switch mode, default, the device operates as a 4-port switch</p>		
6	Converter Mode	2 Pair Mode	Redundant Fiber Mode
	<p>ON: The device operates in Redundant Fiber Mode (when SW 5 is in OFF-Switch mode):</p> <p>SFP1 functions as the primary link SFP2 remains on standby</p> <p>If the link on SFP1 is lost, SFP2 automatically becomes active. When the SFP1 link is restored, it resumes operation as the primary connection.</p> <p>OFF:-2 pair mode- In this mode, the unit operates as two independent media converters: Fiber Port 1 is paired with Copper Port 1, and Fiber Port 2 is paired with Copper Port 2. SW 6 must be in OFF-2 pair Mode.</p>		
7	TP Port 1 PoE Configure	Auto Mode	Force Mode
	<p>ON: Forced Mode: Power is supplied regardless of detection, even if the connected device does not request PoE.</p> <p>OFF: Auto Mode (Default): Complies with IEEE 802.3af/at PoE standards. Power is delivered only when a valid PoE device is detected.</p>		
8	TP Port 2 PoE Configure	Auto Mode	Force Mode
	<p>ON: Forced Mode: Power is supplied regardless of detection, even if the connected device does not request PoE.</p> <p>OFF: Auto Mode (Default): Complies with IEEE 802.3af/at PoE standards. Power is delivered only when a valid PoE device is detected.</p>		

Specifications

Physical Ports	
2 x 10/100/1000Base-T RJ-45 TP Ports (Supports full/half duplex mode)	
2 x 100/1000Base-X SFP Fiber Optic Ports	
PoE	
1 x IEEE 802.3af/at (RJ-45)	
1 x 60W PoE++ (RJ-45) Compatible with 802.3af/at	
LED Indicators	
P1, P2, ALM, Mode, TP1, TP2, PoE1, PoE2	
Power	
Input Voltage	Input Voltage 12~57VDC
Redundant Input power	Dual 12~57VDC on 4-pin terminal block Note the the following guidelines before wiring the device: Use 12~14AWG wire. (15A) for power input
Power consumption	96W (Max.)
Overload current protection	Present
Short Circuit Protection	Present
Relay Alarm	Contact capacity 1A@30V
Physical Characteristic	
Enclosure	IP-30 Metal
Dimension (W x D x H)	36(W) x 110(D) x 135(H) mm (1.42 x 4.33 x 5.31 inch.)
Weight (g)	0.64 Kg
Environmental	
Storage Temperature	-40° to 85°C (-40° to 185°F)
Operating Temperature	-40 to 75 C (-40 to 167 F)
Operating Humidity	5% to 90% Non-condensing
Safety	
FCC Part 15 Class A, CE	
Media	
TP	EIA/TIA-568 CAT 5e
Fiber	Fiber type depends on the MSA compliant SFP purchased separately
Standards	
IEEE 802.3 10Base-T IEEE 802.3u 100Base-TX IEEE 802.3ab 1000Base-T IEEE 802.3z 1000Base-X IEEE802.3af Power over Ethernet IEEE802.3at Power over Ethernet Enhancements	



2+2 Flex PoE+ 10/100/1G
Industrial Ethernet Media Converter
 SFP (100/1G)

EMC-22GP-1



QS-020 2026A

Quick Installation Guide

RLH Industries, Inc
 936 N. Main Street, Orange, CA 92867
 Ph 800-877-1672 info@fiberopticlinc.com



Introduction

The **EMC-22GP-1 Flex PoE++ Ethernet media converter** is a Gigabit Ethernet converter with 2x10/100/1000Base-T 60W PoE Ethernet ports, and 2x100/1000Base-X SFP optical ports with 3 operation modes (Switch, 2 Pair and Fiber Backup). It converts traditional twisted-pair RJ-45 cable into various fiber media including multi-mode, single-mode or bi-directional WDM for various network architecture requirements.

With a wide **12~57 VDC input range using Flex Power technology**, the EMC-22GP-1 is ideal for many applications where 24VDC is readily available, boosting the voltage up to the IEEE 802.3af/at standard of 48-52VDC.

Built to operate reliably in an extended operation temperature range of -40 to 75°C, it has an ITU-T K.21 enhanced test level up to 6KV surge immunity on the RJ-45 copper port, making it ideal for demanding industrial applications.

Features

- ▶ Provide 2 Gigabit RJ-45 Copper Ports & 2 SFP Ports 100/1000Base-X
- ▶ Compatible with IEEE 802.3af/at PoE+
- ▶ PoE Setting - Auto / Force Power
- ▶ Support 9K Jumbo Frames
- ▶ 6KV Surge Immunity on RJ-45 Copper Ports (K.21*)
- ▶ Dual Power Input (12~57VDC) & Built-in Power Booster
- ▶ Supports 3 Operation Modes - Switch Mode, 2 Pair Mode and Fiber Backup Mode.
- ▶ Relay Output for Fault Alarm Notification (Power, Ports)
- ▶ Aluminum Housing
- ▶ Operating Temperature -40°C~75°C

Package Contents

Description	Qty.
2+2 Flex PoE+ 10/100/1G Industrial Ethernet Media Converter, SFP (100/1G)	① x 1
Wall Mount Bracket Kit	
Quick Installation Guide	③ x 1

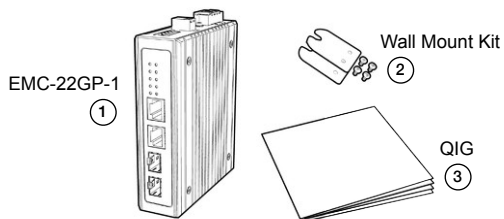

Please contact RLH if any contents are damaged or missing

Installation

- **DIN Rail**
 - ▶ **Step 1:** Attach the DIN rail clip using the screws included in the DIN Rail kit.
 - ▶ **Step 2:** Attach the device to the DIN rail, hooking the spring wires over the top of the rail, then pressing down until the device clicks into the rail firmly.
- **Wall Mount**
 - ▶ **Step 1:** Remove the attached DIN rail clip.
 - ▶ **Step 2:** Attach the two wall mount brackets at the top and bottom of the back of the device.
 - ▶ **Step 3:** Use the device with wall mount plates attached as a guide to mark the correct location for mounting.
 - ▶ **Step 4:** Insert an appropriately sized screw into the middle of the mounting slot on the plate and tighten accordingly.

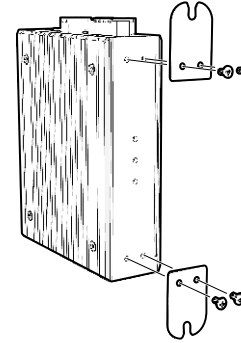

Top Panel

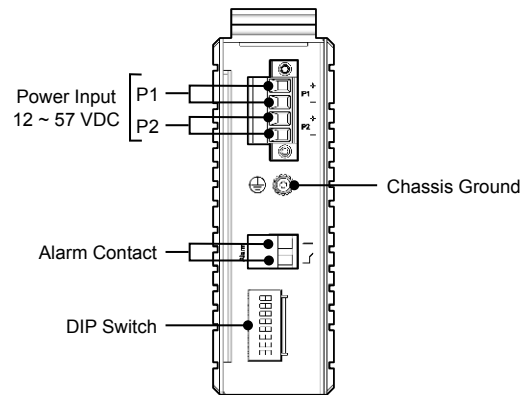

Power Input terminal Block: Two sets of power inputs ranging from DC 12V~57V, P1 and P2, are offered for power redundancy purpose. Use both pairs of the power inputs with separate power supplies for redundancy, or use either single pair as needed. Redundant power inputs will seamlessly switch when one power source is down to protect the device loss of power.

NOTE: Use 14AWG or better power wire when using high power input devices.

Terminal Block 2 Fault Alarm: One pair of fault connection on the terminal block 2 is used to connect alarm devices such as speakers or LEDs to alert users when the port link disconnects and power failure occurs. **NOTE:** Alarm Contact capacity is 1A@30V.

Front Panel

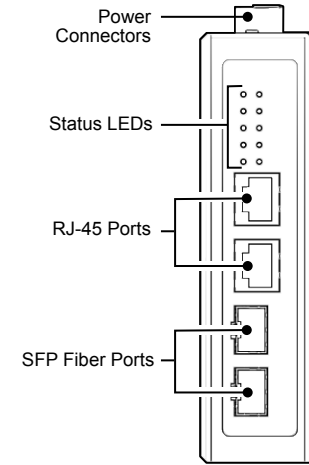

LED	Color	Status	Description
P1, P2 Power	Green	OFF	No Power is present
		ON	Power is Functioning Normally
ALM	Red	OFF	No Alarm is present
		ON	Port Link Failure or Power Failure
Mode	Green	Blinking	System Boot Failure
		OFF	Switch Mode
		ON	Converter Mode - Fiber Backup Mode
TP 1/2	Orange	ON	Converter Mode - 2 Pair Mode
		OFF	TP port link is down
		ON	TP 1000M port link is up
TP 1/2	Green	Blinking	TP port is receiving and transmitting data at 1000M
		ON	TP 10/100M port link is up
PoE 1/2	Orange	Blinking	TP port is receiving and transmitting data at the speed of 10/100M
		OFF	No PSE (Power Sourcing Equipment) is present
		ON	Power (Max. 30W) is supplied through TP 1/2 port (Auto Mode)
SFP 1/2	Green	ON	Enforce supply power through TP 1/2 port (Force Mode)
		ON	TP 1: 60W / TP 2: 30W
		Blinking	Fiber port is receiving and transmitting data at the speed of 1000M
		ON	100M Fiber port link is up
SFP 1/2	Orange	Blinking	Fiber port is receiving and transmitting data at the speed of 100M